

BOR
CARBIDE



BOR CARBIDE
Indexable Drilling Tools

—> Revolutionary innovation, leading drilling & being extraordinary.

Modular Drill



Compared with the traditional U-drills, the newly launched modular drills have the characteristics of a wider application range and more excellent performance. They can save a lot of costs and simplify the processing flow in the application of processing plant workshops.

- Excellent drill tip groove shape and carbide inserts.
- It can be used for the processing and application of materials such as steel, stainless steel, and cast iron.
- It can be used for the processing and application of materials such as steel, stainless steel, and cast iron.



SKD11

Modular Drill

Advantages and characteristics

- Support fast feed drilling processing to ensure a high level of productivity.
- Low drilling force can avoid the bending of the workpiece.
- Even in deep cavity processing, good accuracy can be guaranteed.
- Modular drills have the characteristics of larger diameter and longer effective length.



Processing mode



Drilling



Cross Hole



Convex



Inclined Entry



Through Coolant



Blade information

The crown drill tip can be reground for secondary use, thereby improving economy.

Monolithic carbide inserts offer more options.

From a diameter of 12.5mm to 40mm, with an interval of 0.1mm for each specification.

High-efficiency hole processing can eliminate the rough boring process and be formed in one time.





Double internal cooling spiral water outlet is perfectly combined with the cutter body

Design principle

By adopting a double helix structure in the cooling channel, the contact area and contact time between the coolant and the cooled surface are increased, thereby enhancing the heat exchange efficiency. When the coolant flows in the double helix channel, a strong turbulence is generated, further strengthening the cooling effect.

Excellent clamping design

-  The rear-pull type locking device can prevent the blade from detaching.
-  A larger bearing surface can ensure the safe transmission of large torque and will not cause the deformation of the tool holder.
-  a larger contact surface.

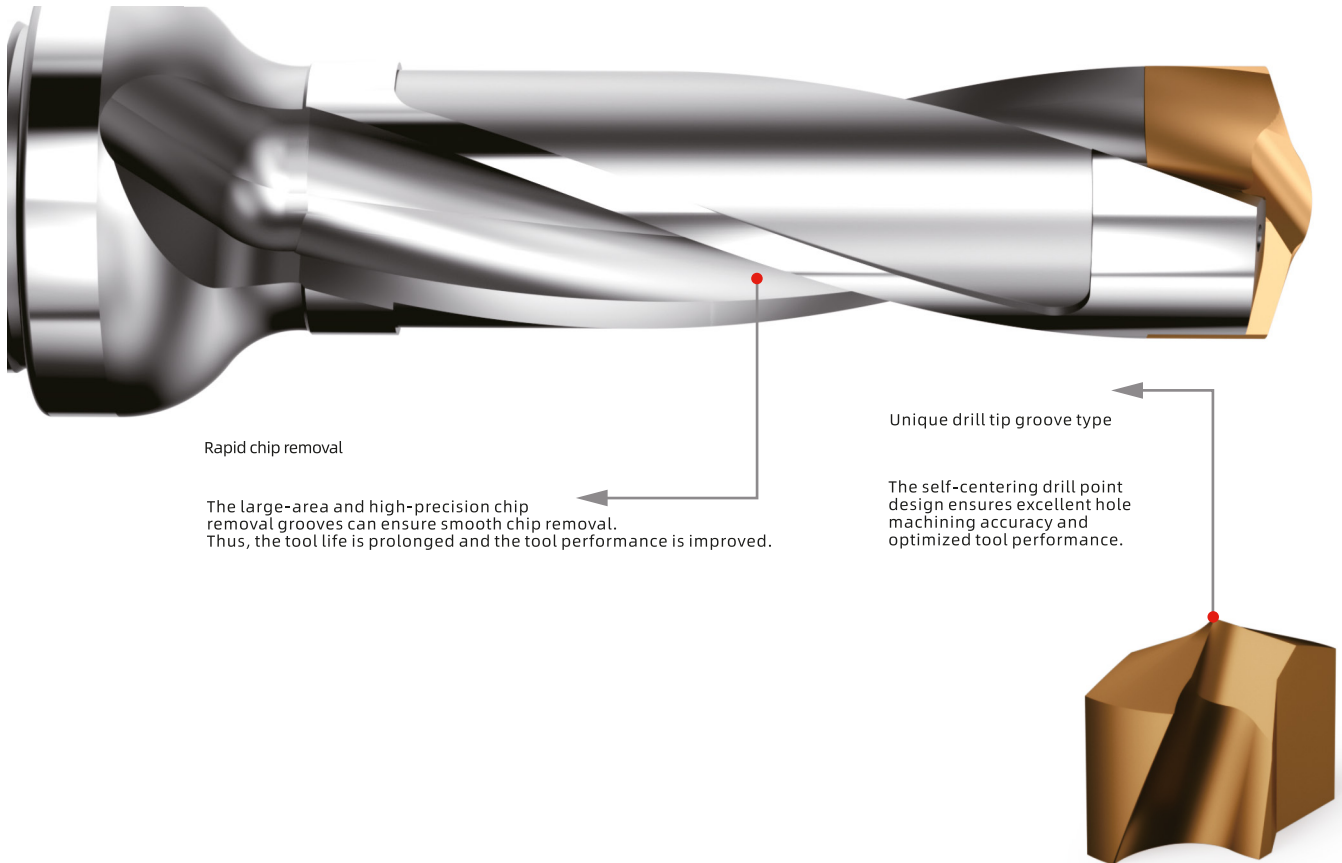
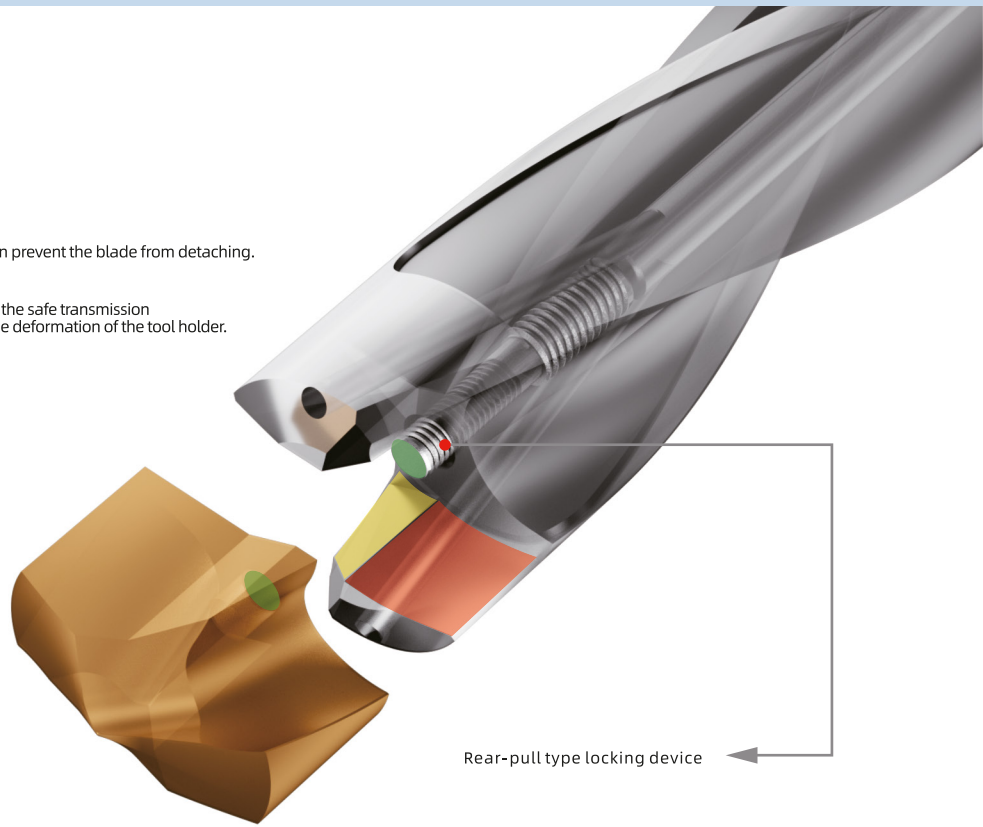

Provide tool grinding service

After the blade wears out, you can participate in our recycling service plan. We offer blade grinding to reduce costs. The ground blades perform as stably and consistently as new ones.

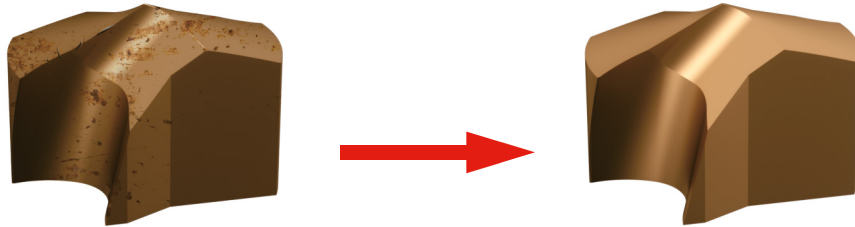

Installation guidance

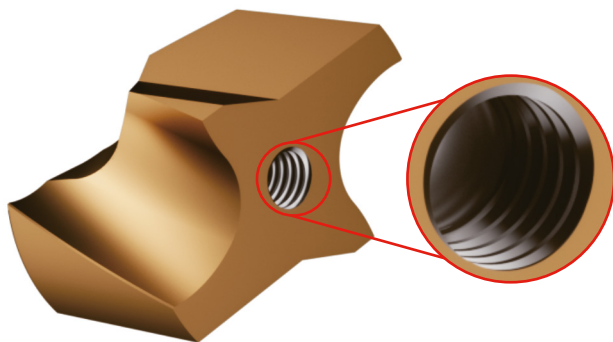
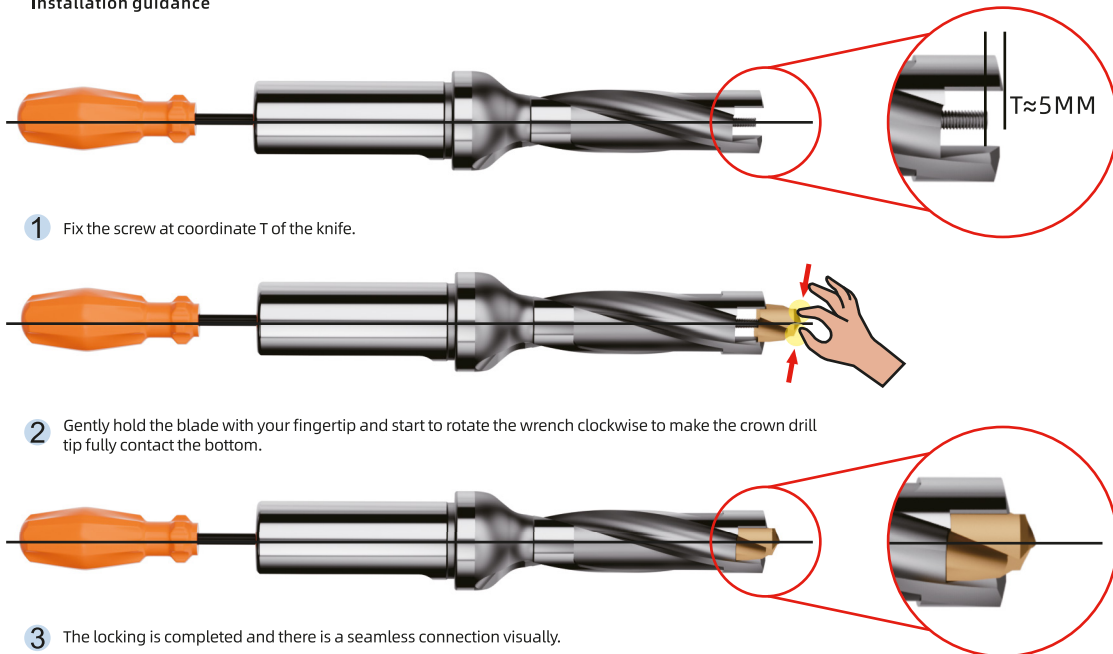

Clamping suggestions

The threaded insert of the blade with the screw-locking part enhances process safety.

During the process of installing the blade, in special cases where it is difficult to install! You can apply anti-seize oil at the thread, which helps to simplify the installation process.

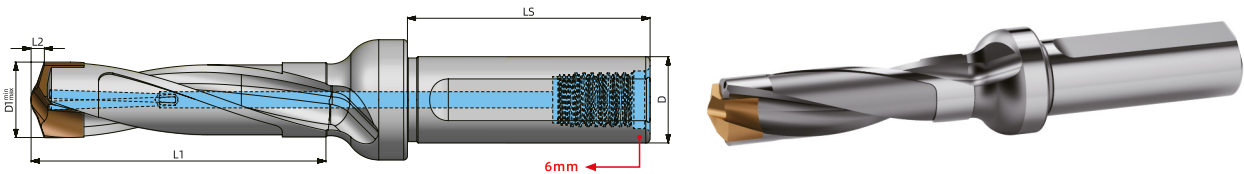

Modular Drill-3D

Cat.No 3D	D1 min	D1 max	type	(L2)	(L5)	Shank diameter / Water connection	(L1)	Center locking screw	Wrench
				Knife tip depth	Handle length		Effective length		
KS-12.5-3D-C16 KSEM125R3WN16M	12.500	12.990	C	2.000	45	16/PC1/8	39	M3.0/M2.5*14	T6*180 3D/5D
KS-13-3D-C16 KSEM130R3WN16M	13.000	13.490	C	2.100	45	16/PC1/8	40.5	M3.0/M2.5*14	T6*180 3D/5D
KS-13.5-3D-C16 KSEM135R3WN16M	13.500	13.990	B	2.100	45	16/PC1/8	42	M3.0/M2.5*14	T6*180 3D/5D
KS-14-3D-C16 KSEM140R3WN16M	14.000	14.490	B	2.200	45	16/PC1/8	43.5	M3.0/M2.5*14	T6*180 3D/5D
KS-14.5-3D-C20 KSEM145R3WN20M	14.500	14.990	A	2.300	50	20/PC1/8	45	M3.0/M2.5*14	T6*180 3D/5D
KS-15-3D-C20 KSEM150R3WN20M	15.000	15.990	A	2.400	50	20/PC1/8	48	M3.0/M2.5*14	T6*180 3D/5D
KS-16-3D-C20 KSEM160R3WN20M	16.000	16.990	1	2.500	50	20/PC1/8	51	M3.5/M2.5*16	1.5*180 3D/5D
KS-17-3D-C20 KSEM170R3WN20M	17.000	17.990	1	2.700	50	20/PC1/8	54	M3.5/M2.5*16	1.5*180 3D/5D
KS-18-3D-C25 KSEM180R3WN25M	18.000	18.990	2	2.900	56	25/PC1/8	57	M4.0/M3.0*19	2.0*210 3D/5D
KS-19-3D-C25 KSEM190R3WN25M	19.000	19.990	2	3.000	56	25/PC1/8	60	M4.0/M3.0*19	2.0*210 3D/5D
KS-20-3D-C25 KSEM200R3WN25M	20.000	20.990	3	3.200	56	25/PC1/8	63	M4.0/M3.0*19	2.0*210 3D/5D
KS-21-3D-C25 KSEM210R3WN25M	21.000	21.990	3	3.300	56	25/PC1/8	66	M4.0/M3.0*19	2.0*210 3D/5D
KS-22-3D-C25 KSEM220R3WN25M	22.000	22.990	4	3.500	56	25/PC1/8	69	M4.0/M3.0*19	2.0*210 3D/5D
KS-23-3D-C25 KSEM230R3WN25M	23.000	23.990	4	3.700	56	25/PC1/8	72	M4.0/M3.0*19	2.0*210 3D/5D
KS-24-3D-C32 KSEM240R3WN32M	24.000	24.990	5	3.800	60	32/PC1/4	75	M5.0/M4.0*23	2.5*240 3D/5D
KS-25-3D-C32 KSEM250R3WN32M	25.000	25.990	5	3.800	60	32/PC1/4	78	M5.0/M4.0*23	2.5*240 3D/5D
KS-26-3D-C32 KSEM260R3WN32M	26.000	26.990	6	4.000	60	32/PC1/4	81	M5.0/M4.0*23	2.5*240 3D/5D
KS-27-3D-C32 KSEM270R3WN32M	27.000	27.990	6	4.200	60	32/PC1/4	84	M5.0/M4.0*23	2.5*240 3D/5D
KS-28-3D-C32 KSEM280R3WN32M	28.000	28.990	7	4.300	60	32/PC1/4	87	M5.0/M4.0*23	2.5*240 3D/5D
KS-29-3D-C32 KSEM290R3WN32M	29.000	29.990	7	4.500	60	32/PC1/4	90	M6.0/M5.0*28	3.0*350 3D/5D
KS-30-3D-C32 KSEM300R3WN32M	30.000	30.990	8	4.600	60	32/PC1/4	93	M6.0/M5.0*28	3.0*350 3D/5D
KS-31-3D-C32 KSEM310R3WN32M	31.000	31.990	8	4.800	60	32/PC1/4	96	M6.0/M5.0*28	3.0*350 3D/5D
KS-32-3D-C40 KSEM320R3WN40M	32.000	32.990	9	4.900	70	40/PC1/4	99	M6.0/M6.0*32	3.0*350 3D/5D
KS-33-3D-C40 KSEM330R3WD40M	33.000	33.990	9	5.100	70	40/PC1/4	102	M6.0/M6.0*32	3.0*350 3D/5D
KS-34-3D-C40 KSEM340R3WD40M	34.000	34.990	9	5.200	70	40/PC1/4	105	M6.0/M6.0*32	3.0*350 3D/5D
KS-35-3D-C40 KSEM350R3WD40M	35.000	35.990	9	5.400	70	40/PC1/4	108	M6.0/M6.0*32	3.0*350 3D/5D
KS-36-3D-C40 KSEM360R3WD40M	36.000	36.990	10	5.500	70	40/PC1/4	111	M6.0/M6.0*32	3.0*350 3D/5D
KS-37-3D-C40 KSEM370R3WD40M	37.000	37.990	10	5.700	70	40/PC1/4	114	M6.0/M6.0*32	3.0*350 3D/5D
KS-38-3D-C40 KSEM380R3WD40M	38.000	38.990	10	5.800	70	40/PC1/4	117	M6.0/M6.0*32	3.0*350 3D/5D
KS-39-3D-C40 KSEM390R3WD40M	39.000	39.990	10	6.000	70	40/PC1/4	120	M6.0/M6.0*32	3.0*350 3D/5D
KS-40-3D-C40 KSEM400R3WD40M	40.000	40.990	10	6.200	70	40/PC1/4	123	M6.0/M6.0*32	3.0*350 3D/5D

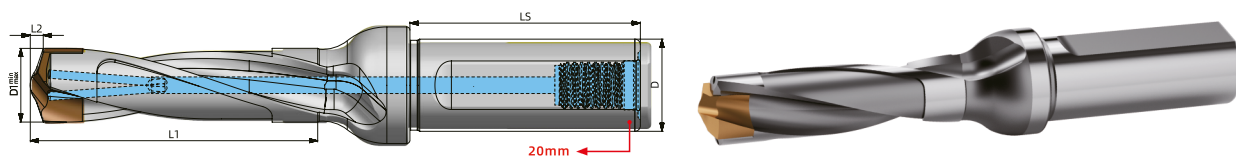

Modular Drill-5D

Cat.No	5D	D1 min	D1 max	type	(L2)	(L5)	Shank diameter / Water connection	(L1)	Center locking screw	Wrench
					Knife tip depth	Handle length		Effective length		
KS-12.5-5D-C16 KSEM125R5WN16M		12.500	12.990	C	2.000	45	16/PC1/8	65	M3.0/M2.5*14	T6*180 3D/5D
KS-13-5D-C16 KSEM130R5WN16M		13.000	13.490	C	2.100	45	16/PC1/8	67.5	M3.0/M2.5*14	T6*180 3D/5D
KS-13.5-5D-C16 KSEM135R5WN16M		13.500	13.990	B	2.100	45	16/PC1/8	70	M3.0/M2.5*14	T6*180 3D/5D
KS-14-5D-C16 KSEM140R5WN16M		14.000	14.490	B	2.200	45	16/PC1/8	72.5	M3.0/M2.5*14	T6*180 3D/5D
KS-14.5-5D-C20 KSEM145R5WN20M		14.500	14.990	A	2.300	50	20/PC1/8	75	M3.0/M2.5*14	T6*180 3D/5D
KS-15-5D-C20 KSEM150R5WN20M		15.000	15.990	A	2.400	50	20/PC1/8	80	M3.0/M2.5*14	T6*180 3D/5D
KS-16-5D-C20 KSEM160R5WN20M		16.000	16.990	1	2.500	50	20/PC1/8	85	M3.5/M2.5*16	1.5*180 3D/5D
KS-17-5D-C20 KSEM170R5WN20M		17.000	17.990	1	2.700	50	20/PC1/8	90	M3.5/M2.5*16	1.5*180 3D/5D
KS-18-5D-C25 KSEM180R5WN25M		18.000	18.990	2	2.900	56	25/PC1/8	95	M4.0/M3.0*19	2.0*210 3D/5D
KS-19-5D-C25 KSEM190R5WN25M		19.000	19.990	2	3.000	56	25/PC1/8	100	M4.0/M3.0*19	2.0*210 3D/5D
KS-20-5D-C25 KSEM200R5WN25M		20.000	20.990	3	3.200	56	25/PC1/8	105	M4.0/M3.0*19	2.0*210 3D/5D
KS-21-5D-C25 KSEM210R5WN25M		21.000	21.990	3	3.300	56	25/PC1/8	110	M4.0/M3.0*19	2.0*210 3D/5D
KS-22-5D-C25 KSEM220R5WN25M		22.000	22.990	4	3.500	56	25/PC1/8	115	M4.0/M3.0*19	2.0*210 3D/5D
KS-23-5D-C25 KSEM230R5WN25M		23.000	23.990	4	3.700	56	25/PC1/8	120	M4.0/M3.0*19	2.0*210 3D/5D
KS-24-5D-C32 KSEM240R5WN32M		24.000	24.990	5	3.800	60	32/PC1/4	125	M5.0/M4.0*23	2.5*240 3D/5D
KS-25-5D-C32 KSEM250R5WN32M		25.000	25.990	5	3.800	60	32/PC1/4	130	M5.0/M4.0*23	2.5*240 3D/5D
KS-26-5D-C32 KSEM260R5WN32M		26.000	26.990	6	4.000	60	32/PC1/4	135	M5.0/M4.0*23	2.5*240 3D/5D
KS-27-5D-C32 KSEM270R5WN32M		27.000	27.990	6	4.200	60	32/PC1/4	140	M5.0/M4.0*23	2.5*240 3D/5D
KS-28-5D-C32 KSEM280R5WN32M		28.000	28.990	7	4.300	60	32/PC1/4	145	M5.0/M4.0*23	2.5*240 3D/5D
KS-29-5D-C32 KSEM290R5WN32M		29.000	29.990	7	4.500	60	32/PC1/4	150	M6.0/M5.0*28	3.0*350 3D/5D
KS-30-5D-C32 KSEM300R5WN32M		30.000	30.990	8	4.600	60	32/PC1/4	155	M6.0/M5.0*28	3.0*350 3D/5D
KS-31-5D-C32 KSEM310R5WN32M		31.000	31.990	8	4.800	60	32/PC1/4	160	M6.0/M5.0*28	3.0*350 3D/5D
KS-32-5D-C40 KSEM320R5WN40M		32.000	32.990	9	4.900	70	40/PC1/4	165	M6.0/M6.0*32	3.0*350 3D/5D
KS-33-5D-C40 KSEM330R5WD40M		33.000	33.990	9	5.100	70	40/PC1/4	170	M6.0/M6.0*32	3.0*350 3D/5D
KS-34-5D-C40 KSEM340R5WD40M		34.000	34.990	9	5.200	70	40/PC1/4	175	M6.0/M6.0*32	3.0*350 3D/5D
KS-35-5D-C40 KSEM350R5WD40M		35.000	35.990	9	5.400	70	40/PC1/4	180	M6.0/M6.0*32	3.0*350 3D/5D
KS-36-5D-C40 KSEM360R5WD40M		36.000	36.990	10	5.500	70	40/PC1/4	185	M6.0/M6.0*32	3.0*350 3D/5D
KS-37-5D-C40 KSEM370R5WD40M		37.000	37.990	10	5.700	70	40/PC1/4	190	M6.0/M6.0*32	3.0*350 3D/5D
KS-38-5D-C40 KSEM380R5WD40M		38.000	38.990	10	5.800	70	40/PC1/4	195	M6.0/M6.0*32	3.0*350 3D/5D
KS-39-5D-C40 KSEM390R5WD40M		39.000	39.990	10	6.000	70	40/PC1/4	200	M6.0/M6.0*32	3.0*350 3D/5D
KS-40-5D-C40 KSEM400R5WD40M		40.000	40.990	10	6.200	70	40/PC1/4	205	M6.0/M6.0*32	3.0*350 3D/5D

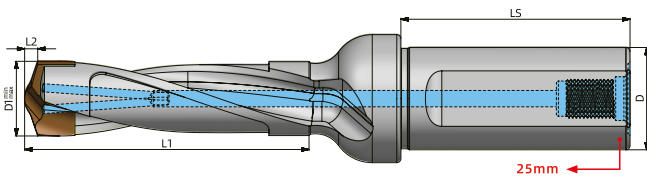

Modular Drill-7D

Cat.No 7D	D1 min	D1 max	type	(L2)	(LS)	Shank diameter / Water connection	(L1)	Center locking screw	Wrench
				Knife tip depth	Handle length		Effective length		
KS-12.5-7D-C16 KSEM125R7WN16M	12.500	12.990	C	2.000	45	16/PC1/8	91	M3.0/M2.5*14	T6*290 7D/10D
KS-13-7D-C16 KSEM130R7WN16M	13.000	13.490	C	2.100	45	16/PC1/8	94.5	M3.0/M2.5*14	T6*290 7D/10D
KS-13.5-7D-C16 KSEM135R7WN16M	13.500	13.990	B	2.100	45	16/PC1/8	98	M3.0/M2.5*14	T6*290 7D/10D
KS-14-7D-C16 KSEM140R7WN16M	14.000	14.490	B	2.200	45	16/PC1/8	101.5	M3.0/M2.5*14	T6*290 7D/10D
KS-14.5-7D-C20 KSEM145R7WN20M	14.500	14.990	A	2.300	50	20/PC1/8	105	M3.0/M2.5*14	T6*290 7D/10D
KS-15-7D-C20 KSEM150R7WN20M	15.000	15.990	A	2.400	50	20/PC1/8	112	M3.0/M2.5*14	T6*290 7D/10D
KS-16-7D-C20 KSEM160R7WN20M	16.000	16.990	1	2.500	50	20/PC1/8	119	M3.5/M2.5*16	1.5*330 7D/10D
KS-17-7D-C20 KSEM170R7WN20M	17.000	17.990	1	2.700	50	20/PC1/8	126	M3.5/M2.5*16	1.5*330 7D/10D
KS-18-7D-C25 KSEM180R7WN25M	18.000	18.990	2	2.900	56	25/PC1/8	133	M4.0/M3.0*19	2.0*280 7D/8D
KS-19-7D-C25 KSEM190R7WN25M	19.000	19.990	2	3.000	56	25/PC1/8	140	M4.0/M3.0*19	2.0*280 7D/8D
KS-20-7D-C25 KSEM200R7WN25M	20.000	20.990	3	3.200	56	25/PC1/8	147	M4.0/M3.0*19	2.0*280 7D/8D
KS-21-7D-C25 KSEM210R7WN25M	21.000	21.990	3	3.300	56	25/PC1/8	154	M4.0/M3.0*19	2.0*280 7D/8D
KS-22-7D-C25 KSEM220R7WN25M	22.000	22.990	4	3.500	56	25/PC1/8	161	M4.0/M3.0*19	2.0*280 7D/8D
KS-23-7D-C25 KSEM230R7WN25M	23.000	23.990	4	3.700	56	25/PC1/8	168	M4.0/M3.0*19	2.0*280 7D/8D
KS-24-7D-C32 KSEM240R7WN32M	24.000	24.990	5	3.800	60	32/PC1/4	175	M5.0/M4.0*23	2.5*320 7D/8D
KS-25-7D-C32 KSEM250R7WN32M	25.000	25.990	5	3.800	60	32/PC1/4	182	M5.0/M4.0*23	2.5*320 7D/8D
KS-26-7D-C32 KSEM260R7WN32M	26.000	26.990	6	4.000	60	32/PC1/4	189	M5.0/M4.0*23	2.5*320 7D/8D
KS-27-7D-C32 KSEM270R7WN32M	27.000	27.990	6	4.200	60	32/PC1/4	196	M5.0/M4.0*23	2.5*320 7D/8D
KS-28-7D-C32 KSEM280R7WN32M	28.000	28.990	7	4.300	60	32/PC1/4	203	M5.0/M4.0*23	2.5*320 7D/8D
KS-29-7D-C32 KSEM290R7WN32M	29.000	29.990	7	4.500	60	32/PC1/4	210	M6.0/M5.0*28	3.0*450 7D/8D
KS-30-7D-C32 KSEM300R7WN32M	30.000	30.990	8	4.600	60	32/PC1/4	217	M6.0/M5.0*28	3.0*450 7D/8D
KS-31-7D-C32 KSEM310R7WN32M	31.000	31.990	8	4.800	60	32/PC1/4	224	M6.0/M5.0*28	3.0*450 7D/8D
KS-32-7D-C40 KSEM320R7WN40M	32.000	32.990	9	4.900	70	40/PC1/4	231	M6.0/M6.0*32	3.0*450 7D/8D
KS-33-7D-C40 KSEM330R7WD40M	33.000	33.990	9	5.100	70	40/PC1/4	238	M6.0/M6.0*32	3.0*450 7D/8D
KS-34-7D-C40 KSEM340R7WD40M	34.000	34.990	9	5.200	70	40/PC1/4	245	M6.0/M6.0*32	3.0*450 7D/8D
KS-35-7D-C40 KSEM350R7WD40M	35.000	35.990	9	5.400	70	40/PC1/4	252	M6.0/M6.0*32	3.0*450 7D/8D
KS-36-7D-C40 KSEM360R7WD40M	36.000	36.990	10	5.500	70	40/PC1/4	259	M6.0/M6.0*32	3.0*450 7D/8D
KS-37-7D-C40 KSEM370R7WD40M	37.000	37.990	10	5.700	70	40/PC1/4	266	M6.0/M6.0*32	3.0*450 7D/8D
KS-38-7D-C40 KSEM380R7WD40M	38.000	38.990	10	5.800	70	40/PC1/4	273	M6.0/M6.0*32	3.0*450 7D/8D
KS-39-7D-C40 KSEM390R7WD40M	39.000	39.990	10	6.000	70	40/PC1/4	280	M6.0/M6.0*32	3.0*450 7D/8D
KS-40-7D-C40 KSEM400R7WD40M	40.000	40.990	10	6.200	70	40/PC1/4	287	M6.0/M6.0*32	3.0*450 7D/8D

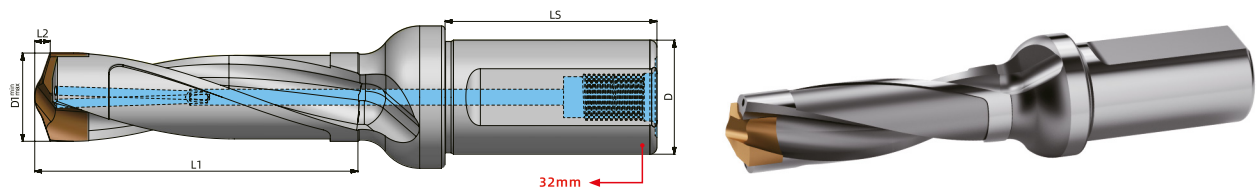

Modular Drill-10D

Cat.No	10D	D1 min	D1 max	type	(L2)	(LS)	Shank diameter / Water connection	(L1)	Center locking screw	Wrench
					Knife tip depth	Handle length		Effective length		
KS-12.5-10D-C16 KSEM125R10WN16M		12.500	12.990	C	2.000	45	16/PC1/8	130	M3.0/M2.5*14	T6*290 7D/10D
KS-13-10D-C16 KSEM130R10WN16M		13.000	13.490	C	2.100	45	16/PC1/8	135	M3.0/M2.5*14	T6*290 7D/10D
KS-13.5-10D-C16 KSEM135R10WN16M		13.500	13.990	B	2.100	45	16/PC1/8	140	M3.0/M2.5*14	T6*290 7D/10D
KS-14-10D-C16 KSEM140R10WN16M		14.000	14.490	B	2.200	45	16/PC1/8	145	M3.0/M2.5*14	T6*290 7D/10D
KS-14.5-10D-C20 KSEM145R10WN20M		14.500	14.990	A	2.300	50	20/PC1/8	150	M3.0/M2.5*14	T6*290 7D/10D
KS-15-10D-C20 KSEM150R10WN20M		15.000	15.990	A	2.400	50	20/PC1/8	160	M3.0/M2.5*14	T6*290 7D/10D
KS-16-10D-C20 KSEM160R10WN20M		16.000	16.990	1	2.500	50	20/PC1/8	170	M3.5/M2.5*16	1.5*330 7D/10D
KS-17-10D-C20 KSEM170R10WN20M		17.000	17.990	1	2.700	50	20/PC1/8	180	M3.5/M2.5*16	1.5*330 7D/10D
KS-18-10D-C25 KSEM180R10WN25M		18.000	18.990	2	2.900	56	25/PC1/8	190	M4.0/M3.0*19	2.0*280 7D/8D
KS-19-10D-C25 KSEM190R10WN25M		19.000	19.990	2	3.000	56	25/PC1/8	200	M4.0/M3.0*19	2.0*280 7D/8D
KS-20-10D-C25 KSEM200R10WN25M		20.000	20.990	3	3.200	56	25/PC1/8	210	M4.0/M3.0*19	2.0*280 7D/8D
KS-21-10D-C25 KSEM210R10WN25M		21.000	21.990	3	3.300	56	25/PC1/8	220	M4.0/M3.0*19	2.0*370 10D/12D
KS-22-10D-C25 KSEM220R10WN25M		22.000	22.990	4	3.500	56	25/PC1/8	230	M4.0/M3.0*19	2.0*370 10D/12D
KS-23-10D-C25 KSEM230R10WN25M		23.000	23.990	4	3.700	56	25/PC1/8	240	M4.0/M3.0*19	2.0*370 10D/12D
KS-24-10D-C32 KSEM240R10WN32M		24.000	24.990	5	3.800	60	32/PC1/4	250	M5.0/M4.0*23	2.5*420 10D/12D
KS-25-10D-C32 KSEM250R10WN32M		25.000	25.990	5	3.800	60	32/PC1/4	260	M5.0/M4.0*23	2.5*420 10D/12D
KS-26-10D-C32 KSEM260R10WN32M		26.000	26.990	6	4.000	60	32/PC1/4	270	M5.0/M4.0*23	2.5*420 10D/12D
KS-27-10D-C32 KSEM270R10WN32M		27.000	27.990	6	4.200	60	32/PC1/4	280	M5.0/M4.0*23	2.5*420 10D/12D
KS-28-10D-C32 KSEM280R10WN32M		28.000	28.990	7	4.300	60	32/PC1/4	290	M5.0/M4.0*23	2.5*420 10D/12D
KS-29-10D-C32 KSEM290R10WN32M		29.000	29.990	7	4.500	60	32/PC1/4	300	M6.0/M5.0*28	3.0*515 10D/12D
KS-30-10D-C32 KSEM300R10WN32M		30.000	30.990	8	4.600	60	32/PC1/4	310	M6.0/M5.0*28	3.0*515 10D/12D
KS-31-10D-C32 KSEM310R10WN32M		31.000	31.990	8	4.800	60	32/PC1/4	320	M6.0/M5.0*28	3.0*515 10D/12D
KS-32-10D-C40 KSEM320R10WN40M		32.000	32.990	9	4.900	70	40/PC1/4	330	M6.0/M6.0*32	3.0*515 10D/12D
KS-33-10D-C40 KSEM330R10WD40M		33.000	33.990	9	5.100	70	40/PC1/4	340	M6.0/M6.0*32	3.0*515 10D/12D
KS-34-10D-C40 KSEM340R10WD40M		34.000	34.990	9	5.200	70	40/PC1/4	350	M6.0/M6.0*32	3.0*515 10D/12D
KS-35-10D-C40 KSEM350R10WD40M		35.000	35.990	9	5.400	70	40/PC1/4	360	M6.0/M6.0*32	3.0*515 10D/12D
KS-36-10D-C40 KSEM360R10WD40M		36.000	36.990	10	5.500	70	40/PC1/4	370	M6.0/M6.0*32	3.0*515 10D/12D
KS-37-10D-C40 KSEM370R10WD40M		37.000	37.990	10	5.700	70	40/PC1/4	380	M6.0/M6.0*32	3.0*515 10D/12D
KS-38-10D-C40 KSEM380R10WD40M		38.000	38.990	10	5.800	70	40/PC1/4	390	M6.0/M6.0*32	3.0*515 10D/12D
KS-39-10D-C40 KSEM390R10WD40M		39.000	39.990	10	6.000	70	40/PC1/4	400	M6.0/M6.0*32	3.0*515 10D/12D
KS-40-10D-C40 KSEM400R10WD40M		40.000	40.990	10	6.200	70	40/PC1/4	410	M6.0/M6.0*32	3.0*515 10D/12D

BOR CARBIDE



Yakuplu Mah. Hürriyet Bulvarı Skyport Residence
No: 1 Kat: 3 No: 64-65 Beylikdüzü / İstanbul



0850 309 14 72



0850 522 34 03



www.borcarbide.com